

**THE INSTITUTE OF FLOWMEASUREMENT
TECHNOLOGY *ELKORA***

**Cross-correlation ultrasonic flowmeter
*ELKORA S-25***

**Operating Manual
E1.005 OM V7.**

2013

Safety Instructions

- Installation and maintenance must only be carried out by suitably trained personnel.
- All relevant sections of this manual must be read before selecting a location.
- Safety requirements of this equipment, any associated equipment and the local environment must be taken into consideration.
- The installation and use of this equipment must be in accordance with relevant national and local standards.

CONTENTS

1 Introduction	4
2 Mechanical Installations	5
2.1 Flow sensor	5
2.2 Transmitter	6
3 Electrical Installations	7
3.1 Input/Output connections	7
3.2 Flow sensor and power supply connections	8
3.3 Relay, pressure sensor, current output, frequency and pulse output connections	9
3.4 Modem or computer connection.	10
4 Technical Data	11
4.1 Flow sensor	11
4.2 Transmitter	12
4.3 Measuring ranges.	13
5 Operation	14
5.1 ELKORA S-25 functions.	16

1 Introduction

The cross-correlation ultrasonic flowmeter *ELKORA 2-25* is designed to measure the flow rate and quantity of potable and industrial water as well as of heavily polluted liquids such as sewage. *ELKORA S-25* has no moving elements and thus a long working life.

A measuring system consists of:

- *ELKORA S-25* transmitter (see fig. 1.1)
- flow sensors (max. 2 units) (see fig. 1.2)



Fig. 1.1 ELKORA S-25 transmitter



Fig. 1.2 ELKORA S-25 flow sensor

2 Mechanical Installations

2.1 Flow sensor

The following recommendations should be kept in mind when installing the flow sensor in the pipeline.

- In order to achieve optimum measurement accuracy, the internal diameters of the flow sensor and the pipeline should be identical.
- Inlet and outlet pipe sections should be of sufficient length:
 - Inlet sections: min. 10 x DN
 - Outlet sections: min. 5 x DN

Where flow disturbances such as pipe elbows, reducers, expanders, etc. are located upstream of the measuring point, longer inlet sections are required. Wherever possible the regulation and control units such as valves should be installed downstream of the sensor.

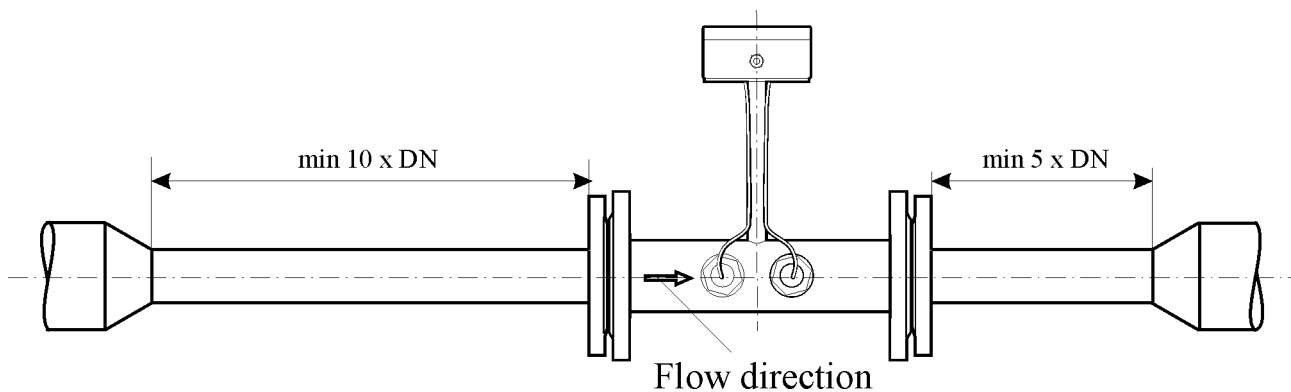

Fig. 2.1 Inlet and outlet sections

- The flow sensor can be installed at any location in the piping system and should always be completely filled with fluid and never be empty.
- The internal diameters of the gaskets should have the same size as the pipe (fig. 2.2).

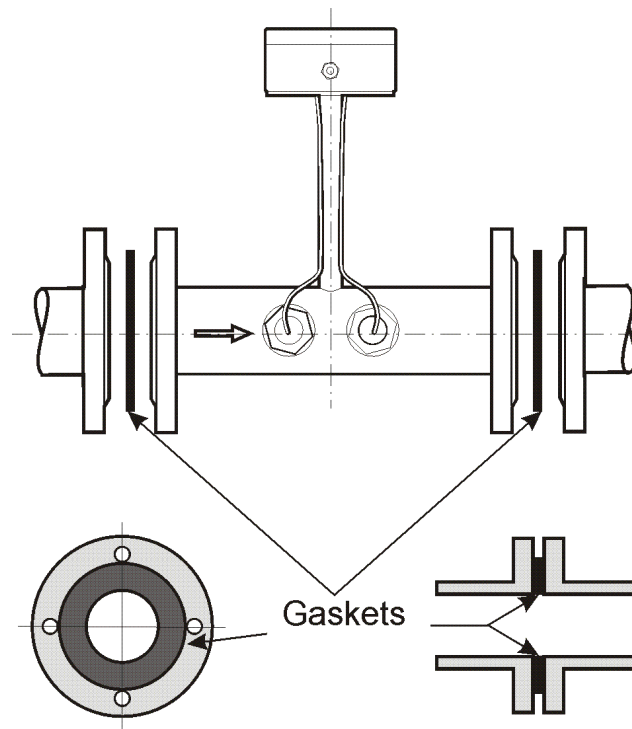

Fig. 2.2 Gasket fitting

- The flow direction in the pipeline should agree with the direction of the arrow on the flow sensor.

2.2 Transmitter

The transmitter is mounted directly on a wall or inside a shielded box using screws. ELKORA C-30 transmitter dimensions are shown on the figure 2.3.

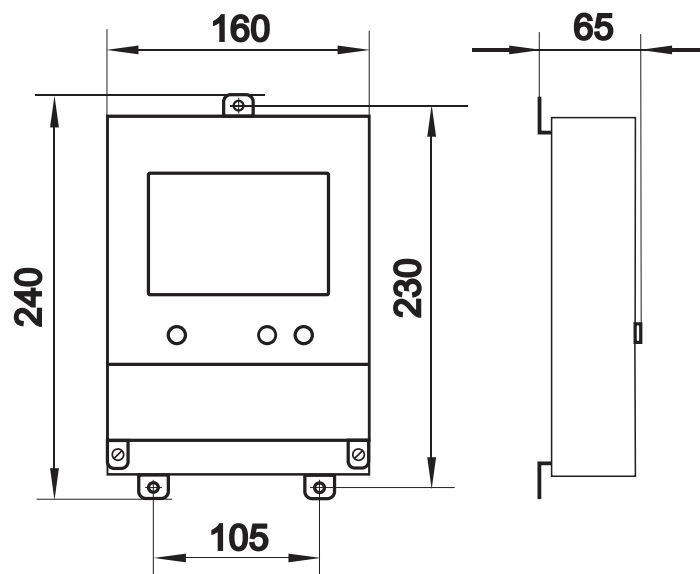

Fig. 2.3 Transmitter dimensions

3 Electrical Installations

3.1 Input/Output connections

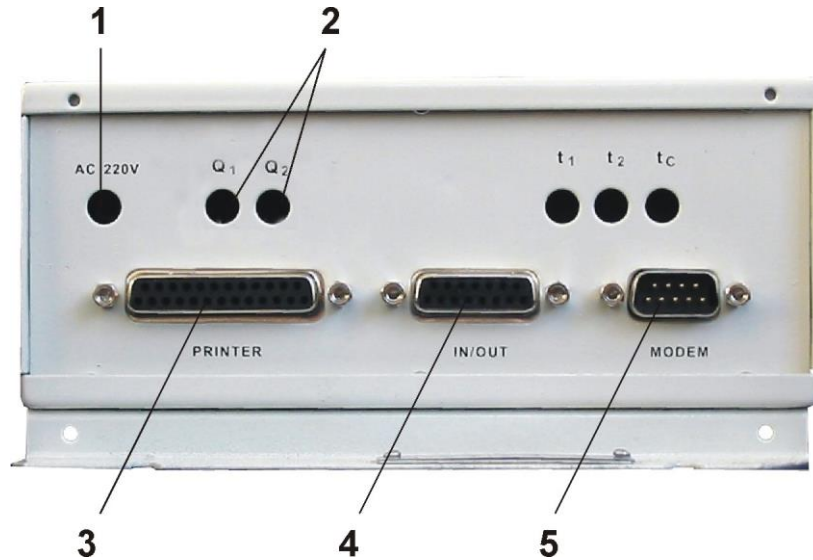

Fig. 3.1 *ELKORA S-25* transmitter bottom view

- 1 – Input for power supply (100 V – 240 V; 50 Hz – 60 Hz)
- 2 – Input for flow sensors **Q₁** and **Q₂**
- 3 – Printer port (Centronics interface) **PRINTER**
- 4 – Relay, pressure sensors, current output, frequency and pulse output **IN/OUT**
- 5 – Serial data port RS-232C, **MODEM**

3.2 Flow sensors and power supply connections

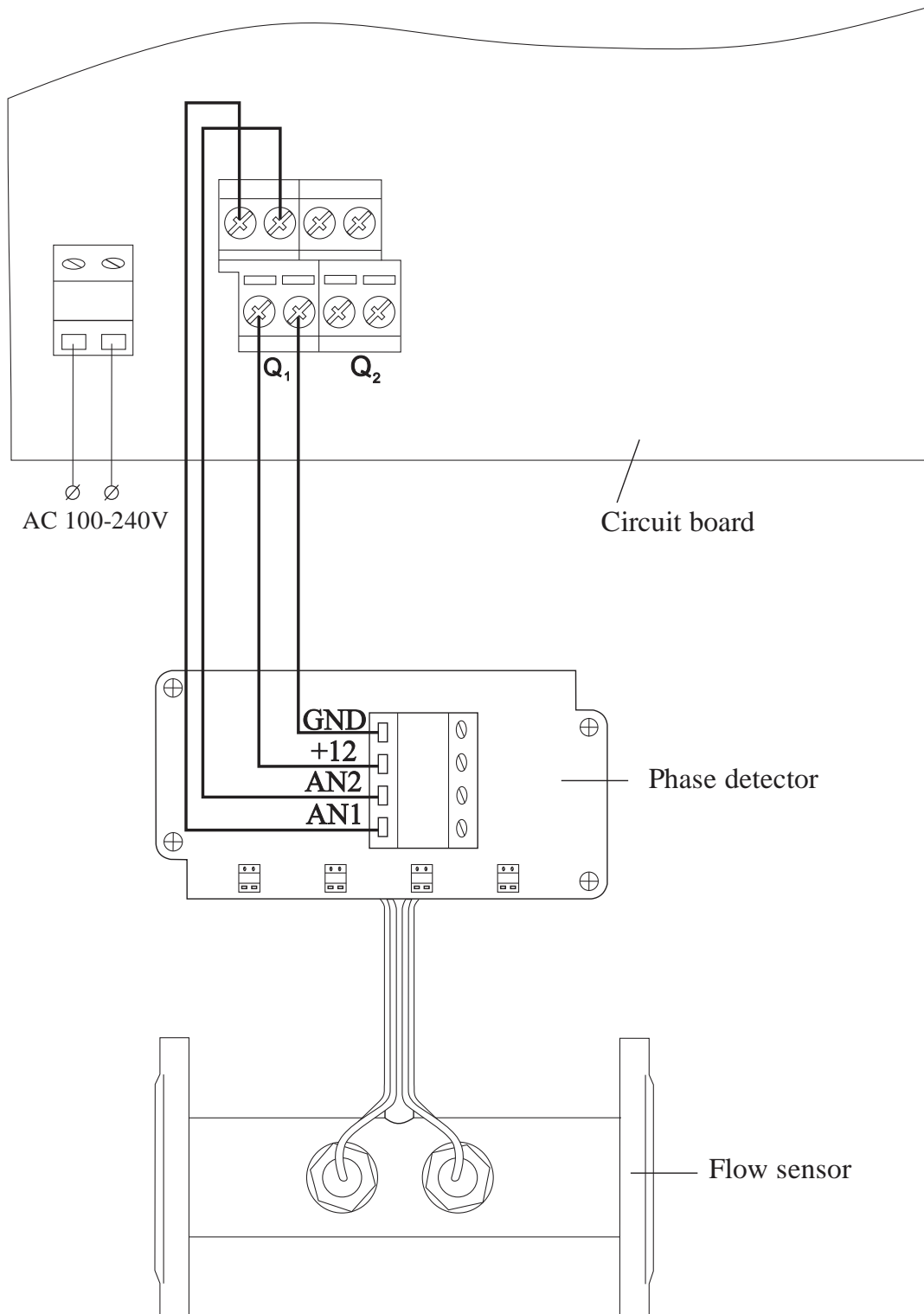

Fig. 3.2 Flow sensor and power supply connections

Signal Cable: 3 - conductor shielded cable; max. cable length between sensor and transmitter is 500 m.

3.3 Relay, pressure sensor, current output, frequency and pulse output connections

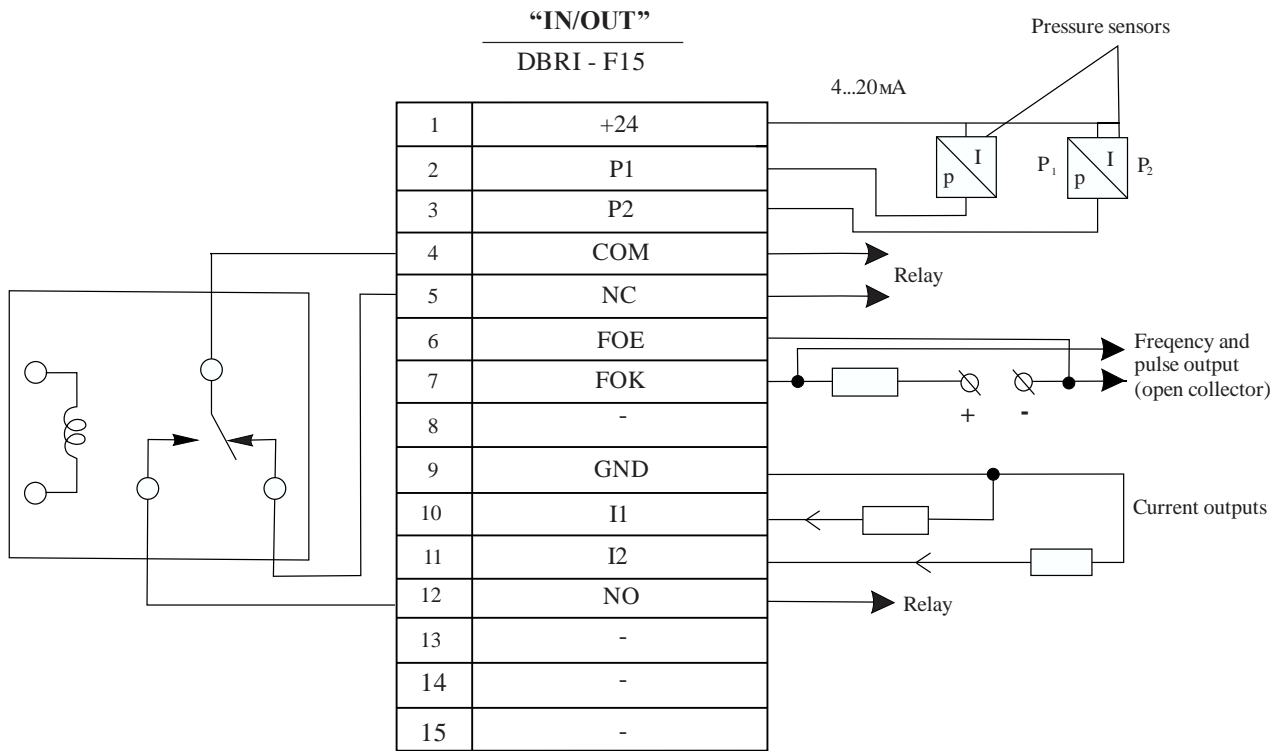

Fig. 3.3 Relay, pressure sensor, current output, frequency and pulse output connections

3.4 Modem or computer connection

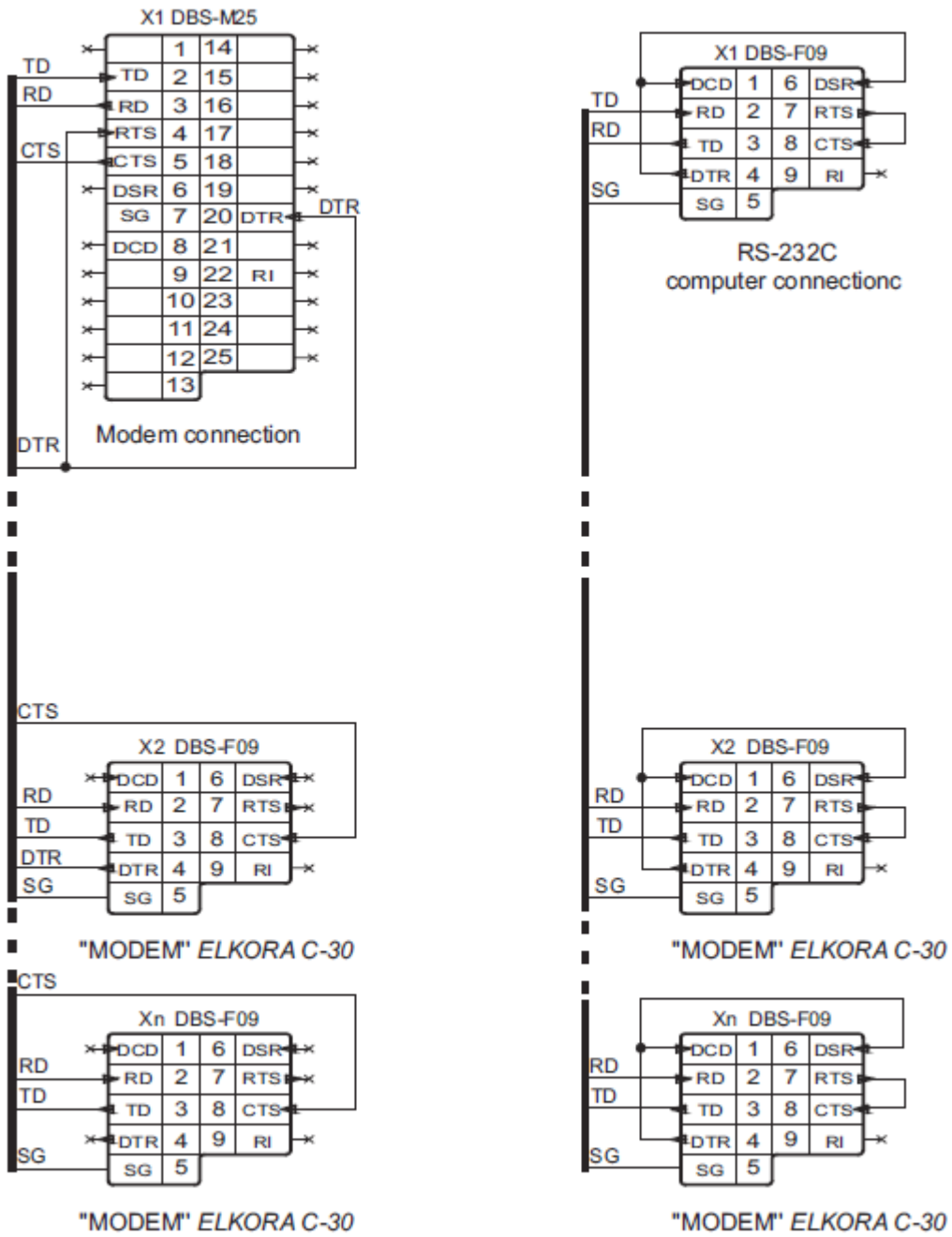

Fig. 3.4 Modem or computer connection

4 Technical Data

4.1 Flow sensor

Flow sensor dimensions and weight are shown in table 4.1 for different sizes. Nominal pressure: 10 bar, ANSI 150 lbs.

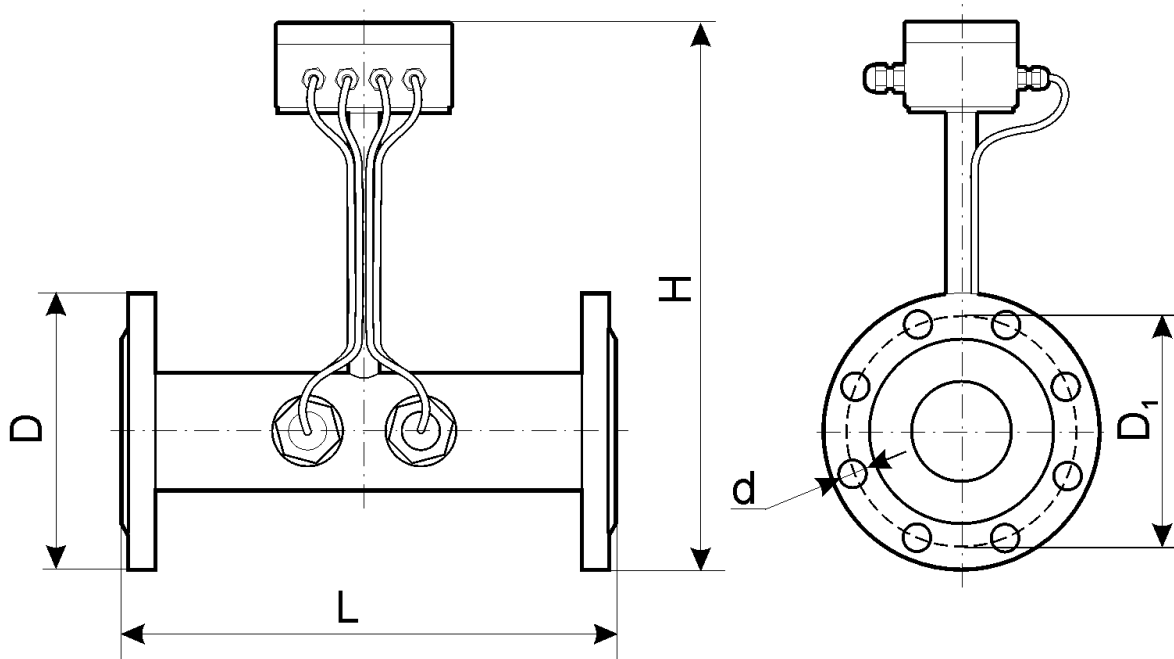

Fig. 4.1 Dimensions of flow sensor *ELKORA S-25*

Table 4.1

DN	Size	L, mm	H, mm	D, mm	D ₁ , mm	d	Weight, kg
	ANSI						
50	2"	300	370	160	125	18	9
65	2½"	300	388	180	145	18	11
80	3"	350	402	195	160	18	13
100	4"	350	425	215	180	18	16
125	5"	350	449	245	210	18	19
150	6"	500	484	280	240	22	30
200	8"	500	537	335	295	22	37
250	10"	600	599	405	355	26	64

4.2 Transmitter

ELKORA S-25 transmitter dimensions are shown in figure 4.2.

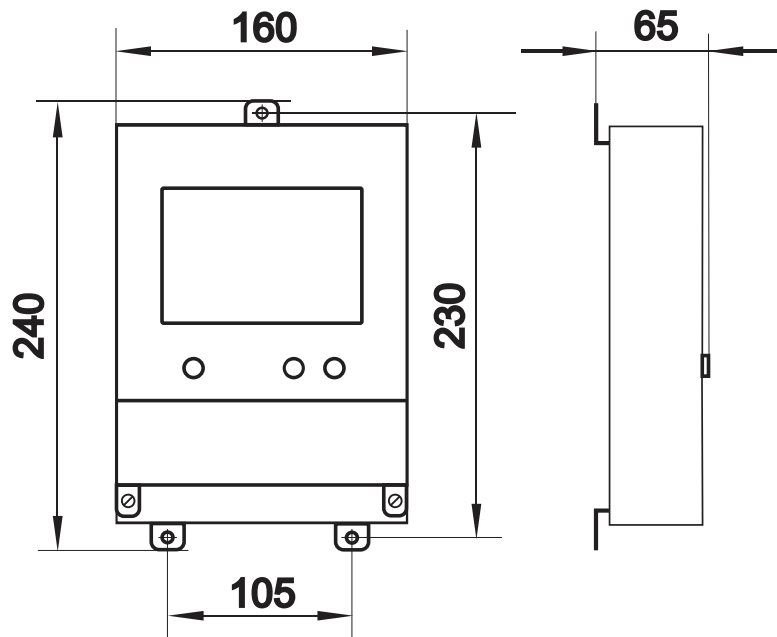

Fig.4.2 ELKORA S-25 transmitter dimensions

Weight	1,5 kg
Ambient temperature	+5... + 55 °C
Power supply	100 V – 240 V; 50 Hz – 60 Hz
Power consumption	< 6 VA
Frequency and pulse outputs	$I_{\max} < 20 \text{ mA}$, $f_{\max} = 32000\text{Hz}$
Current outputs	4...20, 0...5, 0...20 mA
Data links	RS-232C, interface Centronics

4.3 Measuring ranges

Size		Q _{min} , m ³ /h	Q _{max} , m ³ /h	K _δ *
DN	ANSI			
50	2"	0,300	60	1
65	2½"	0,500	100	1
80	3"	0,800	160	1
100	4"	1,20	240	1
125	5"	2,00	400	1
150	6"	3,00	600	2/3
200	8"	5,00	1000	2/3
250	10"	8,00	1600	2/3
300	12	12,0	2400	2/3
400	16	20,0	4000	0,5
500	20	30,0	6000	0,5
600	24	50,0	10000	0,5
800	30	80,0	16000	0,5
1000	40	120	24000	0,5
1200	48	200	40000	0,5
1600	64	320	64000	0,5
1800	72	400	80000	0,5
2000	80	480	96000	0,5

*□K_δ - relative distance coefficient

5 Operation

The *ELKORA S-25* is operated with three buttons: \uparrow , \downarrow and **ON** and uses a local LCD display.

Using the \uparrow and \downarrow buttons the following parameters can be displayed:

- flowrate
- pressure
- volume
- expend time
- time and date

Also, the following archive parameters can be displayed:

- To view **the average per hour flowrate** values (768 hour archive):
 - Use the \uparrow or \downarrow buttons to select the **FLOW RATE** parameter.
 - Press the **ON** button; the left part of the LCD display will show the hour, date and month; the right will show the average for the selected hour flowrate value.
 - Use the \uparrow or \downarrow buttons to select the required hour, date, and month.
 - To quit this mode press the **ON** button or wait for 30 seconds.
- To view **the average per day flow rate** values (96 day archive):
 - Use the \uparrow or \downarrow buttons to select the **FLOW RATE** parameter.
 - Press the **ON** button twice; the left part of the LCD display will show the date, month and year; the right will show the average for the selected day flow rate value.
 - Use the \uparrow or \downarrow buttons to select the required date and month.
 - To quit this mode press the **ON** button or wait for 30 seconds.
- To view **the total per month volume** values (32 month archive):
 - Use the \uparrow or \downarrow buttons to select the **VOLUME** parameter.
 - Press the **ON** button; the left part of the LCD display will show the month and year; the right will show the total for the selected month volume value.
 - Use the \uparrow or \downarrow buttons to select the required month and year.
 - To quit this mode press the **ON** button or wait for 30 seconds.

- To view **the total per day volume** values (96 day archive):
 - Use the ↑ or ↓ buttons to select the **VOLUME** parameter.
 - Press the **ON** button twice; the left part of the LCD display will show the day and month; the right will show the total for the selected day volume value.
 - Use the ↑ or ↓ buttons to select the required day and month.
 - To quit this mode press the **ON** button or wait for 30 seconds.

- To view **the down time per month** (32 month archive):
 - Use the ↑ or ↓ buttons to select the **OPERATING TIME** parameter.
 - Press the **ON** button; the left part of the LCD display will show the month and year; the right will show the down time during the selected month.
 - Use the ↑ or ↓ buttons to select the required month and year.
 - To quit this mode press the **ON** button or wait for 30 seconds.

- To view **the down time per day** (from 96 day archive):
 - Use the ↑ or ↓ buttons to select the **OPERATING TIME** parameter.
 - Press the **ON** button; the left part of the LCD display will show the day and month; the right will show down time during the selected day.
 - Use the ↑ or ↓ buttons to select required month and year.
 - To quit this mode press the **ON** button or wait for 30 seconds.

Note!

10.01* 395.45

If symbol * appears after the date, it indicates that during this period (hour, day or month) there was a loss of power supply.

23 11.08* Power

If **Power** instead of parameter value appears, it indicates loss of power supply during **all** the period indicated in the left part of the LCD display (hour, day or month).

00 12.08 2.19*

If symbol * appears after the parameter value, it indicates that during the period indicated in the left of the LCD display (hour, day or month) the corresponding

sensors were out of order.

5.1 *ELKORA C-30* functions

This section gives the information required for using the individual functions of the *ELKORA S-25*.

To enter the functions setting mode:

- Use the \uparrow and \downarrow buttons to select the **TIME AND DATE** parameter.
- Press the **ON** button continuously for longer than 3 seconds; the functions setting mode is then accessed.
- Use the \uparrow and \downarrow buttons to select the number of the function (the flashing number in the left part of the LCD display).
- Press the **ON** button first and then use the \uparrow and \downarrow buttons to select the function parameter.
- To set other functions press the **ON** button.
- To quit function setting mode press the **ON** button twice or wait for 30 seconds.

Printing mode settings

01 Printing format

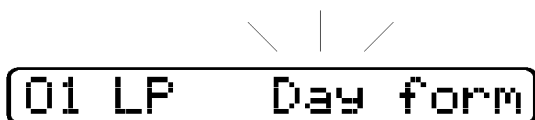

01 LP Day form

Average and total per hour parameter values during one day

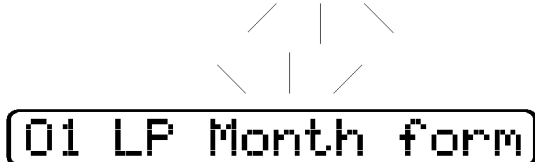

01 LP Month form

Average and total per day parameter values during one month



01 LP Year form

Average and total per month parameter values during one year

02 Printing start time

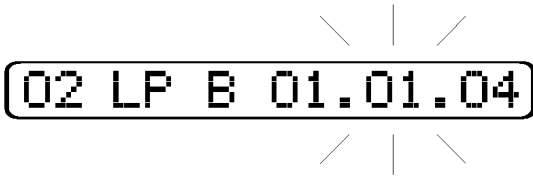

Printing start time settings (hour, day, month, year, depending on the **01** function)

03 Start/Stop printing

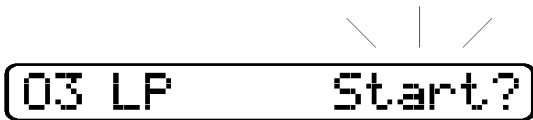

Start printing using the ↑ or ↓ button

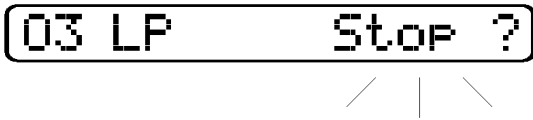

Stop printing using the ↑ or ↓ button

Modem mode settings

10 Master/Slave



The **Master** parameter must be set if only one flowmeter is connected to the modem. If more than one flowmeter is connected to the modem, then the **Master** parameter must be set only for the flowmeter directly connected to the modem; the others flowmeters must be set to **Slave**.

11 Serial port baud rate



Serial port baud rate setting: 1200; 2400; 4800; 9600; 19200; 38400 bit/s.

12 Stop bits and parity

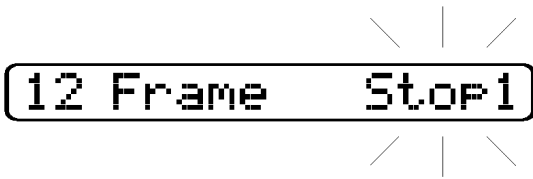

Stop bits and parity settings.
The following parameters are available:

Stop1 – one stop bit, no parity check

Stop2 – two stop bits, no parity check

Parity – one stop bit, parity check

13 Data transfer protocols

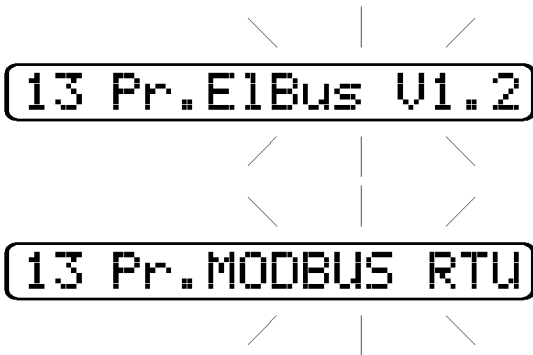

Elkora manager data transfer protocol setting

Modbus standard protocol setting

Current output settings

20 Current output range

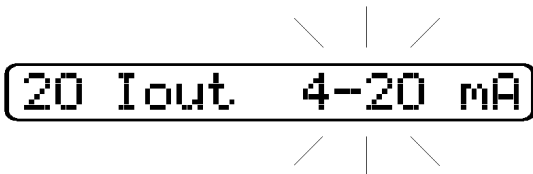

Current output range settings:
4...20, 0...5, 0...20 mA

21, 23 Current outputs 1 and 2 measured parameters, respectively

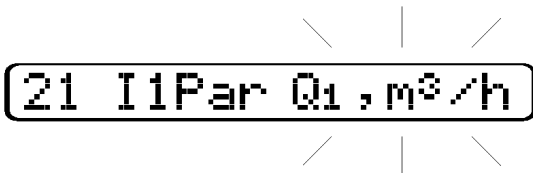

Setting of the measured parameter for current output 1. The following parameters are available: Q₁, Q₂, ΔQ [m³/h]; G₁, G₂, ΔG [t/h]; p₁, p₂ [bar]

22, 24 Current outputs 1 and 2 parameters maximum value, respectively



Maximum measured parameter value setting for current output 1

Frequency and pulse output settings

30 Frequency/Pulse output

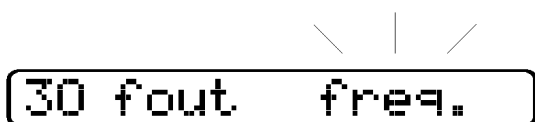

30 fout freq.

Frequency output setting

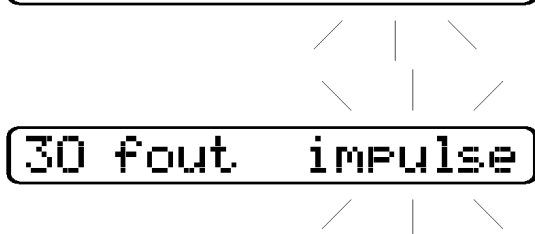

30 fout impulse

Pulse output setting

Functions **31**, **32**, and **33** are only available if the setting **freq.** is selected in function **30**.

31 Maximum frequency

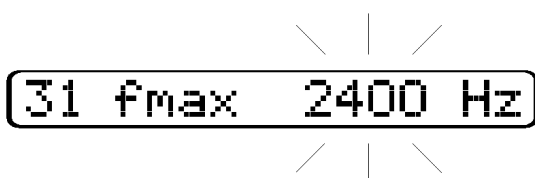

31 fmax 2400 Hz

Maximum frequency setting for frequency output. Available frequency range: 10 Hz – 32000Hz

32 Frequency output measured parameters

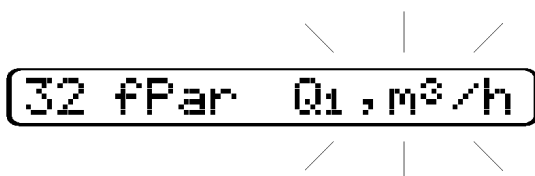

32 fPar Q1, m³/h

Setting of the measured parameter for frequency output. The following parameters are available: Q₁, Q₂, ΔQ [m³/h]; G₁, G₂, ΔG [t/h]; p₁, p₂ [bar]

33 Frequency output measured parameter maximum value



33 fParmax 240

Setting of the measured parameter value corresponding to the maximum frequency, see **31**

Functions **34**, **35** and **36** are only available if the setting **impulse** is selected in function **30**.

34 Pulse output measured parameters

34 iPar V_1, m^3

Setting of the measured parameter for the pulse output. The following parameters are available:

$V_1, V_2, \Delta V [m^3]; M_1, M_2, \Delta M [t]$

35 Pulse output pulse value

35 iVol 0,00010

Pulse value (m^3 /pulse or t/pulse depending on 34) setting. Minimum value depends on DN.

36 Output pulse length

36 iLn9 1 ms

Pulse length setting for pulse output

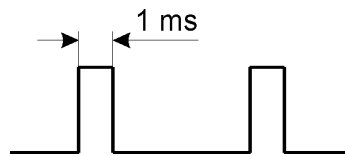

Clock settings

50 hour

51 minute

52 second

53 day

54 month

55 year

ELKORA SIA
Jelgavas iela 42, Riga, LV-1004, Latvia
Phone: + 371 67381156, Fax: + 371 67382584,
e-mail: elkora@elkora.lv, www.elkora.lv